

8/S5
v 3.3 (en)

AIR CURTAINS

XS



TABLE OF CONTENTS

XS.....	475
Dimensions.....	479
Control.....	480
Installation and assembly.....	481
Accessories.....	483
Other accessories.....	485
Wiring diagram.....	491
Ordering key.....	492



XS

BASIC FEATURES

- Lengths: 1.65; 2.20 and 2.75 m
- AC Version: Air flow up to 18500 m3/h (ISO 27 327-1)
- EC Version: Air flow up to 19000 m3/h (ISO 27 327-1)
- Straw System exhaust with maximized screening effect thanks to the laminar air flow
- Horizontal and vertical installation with the adjustable exhaust available by air curtain holders
- Maintenance-free air curtain with a long service life
- Fast and easy connection of individual modules
- Option to choose from 4 types of regulation
- Standard version with galvanized casing or in RAL 9010 (any RAL – based colours may be upon the customer's request)
- The XS is a high-performance industrial curtain for vertical and horizontal installation for use in manufacturing halls, warehouses and other industrial buildings with a recommended installation height / width up to 8 m. The air curtain shall be installed indoors in a dry area with ambient temperatures ranging from (+5 °C)* up to +40 °C and relative humidity of up to 80 %. It is designed for conveying air free of rough dust, grease, chemical fumes, and other impurities. The IP rating of air curtains without a heater and with water heating is IP44. The IP rating of the air curtain with the electric heating is IP 20. The fans comply with requirements of IP 44. The air curtain project shall always be developed by the HVAC designer.

PRIMARY PARAMETERS

- Air curtains with an electric heater are fitted with safety thermostats. Fan motors are equipped with thermal contacts, which can be used to turn off the air curtain in case of the overheating of the motor. The warm-water exchangers are designed for maximum operating water temperature of +110 °C and a maximum operation pressure of 1.6 MPa.

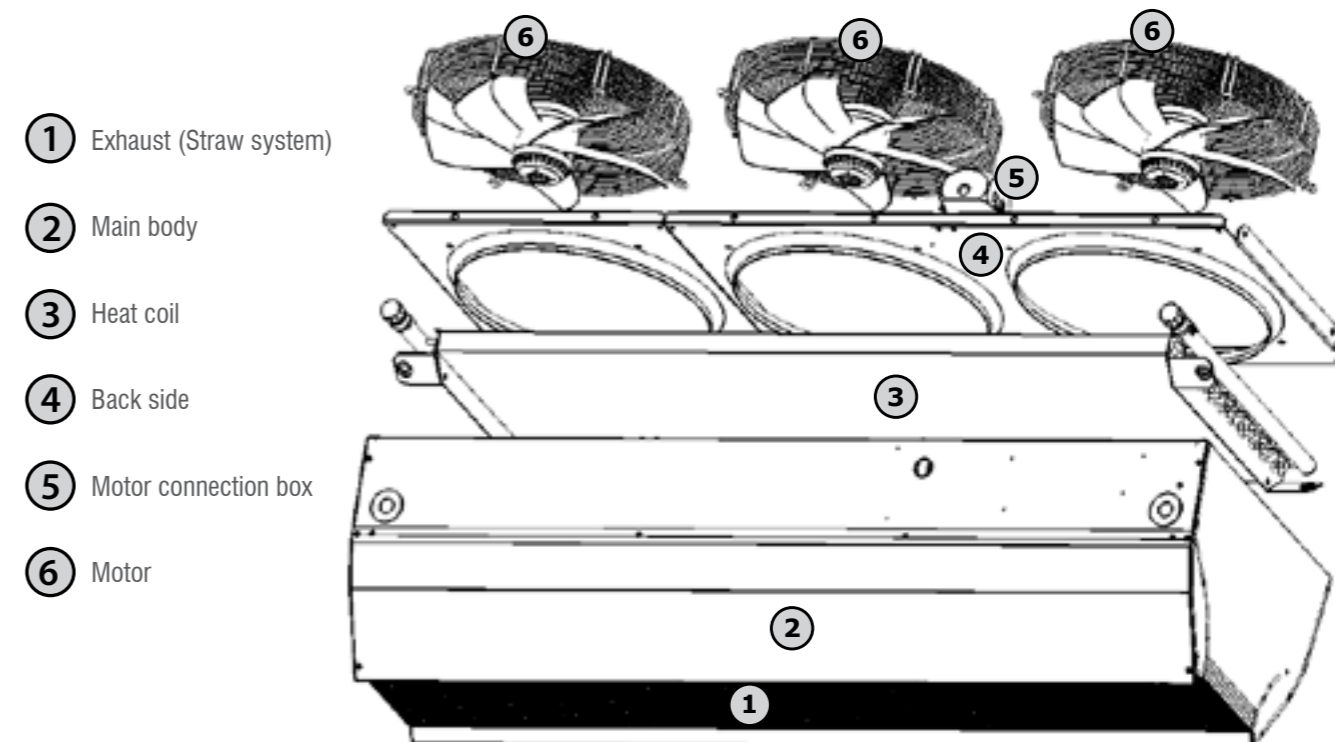

Air curtain type	Recommended installation height [m]	Air capacity [m³/h] *1		Noise [dB(A)] *2				Sound power [dB(A)] *3	Heater power [kW]	Total consumption [V/A]	Electric heater consumption [V/A]			Weight [kg] *5
		50Hz	60Hz	3 m		5 m					[V]	[A] 50Hz	[A] 60Hz	
				50Hz	60Hz	50Hz	60Hz							
XS-15-N-AC	7,5	11550	11520	67,5	67,9	63,0	63,9	85	-	-	230	3,9	3,98	51
XS-15-N-EC	7,5	11400	11400	67,6	67,6	63,1	63,1	84	-	-	230	6,5	6,5	51
XS-15-W-AC	7,5	10300	10270	67,5	67,5	63,1	63,5	85	-	-	230	3,9	3,96	60
XS-15-W-EC	7,5	10500	10500	67,6	67,6	63,2	63,2	84	-	-	230	6,6	6,6	60
XS-15-E25-AC	7,5	11550	11520	67,5	67,9	63,0	63,9	85	9,5	400/35,2	230	3,9	3,96	55
XS-15-E25-EC	7,5	11400	11400	67,6	67,6	63,1	63,1	84	15	400/35,2	230	6,5	6,5	55
XS-20-N-AC	8,0	15100	15070	69,3	69,8	64,9	65,3	86,8	19	-	230	5,1	5,2	69
XS-20-N-EC	8,0	15200	15200	69,4	69,4	64,9	64,9	85,7	24,5	-	230	8,6	8,6	69
XS-20-W-AC	8,0	13700	13670	68,4	69,7	64,0	64,5	85,9	16,97*4	-	230	5,4	5,5	78
XS-20-W-EC	8,0	14000	14000	68,5	68,5	64,1	64,1	84,8	38,47*4	400/47,0	230	8,8	8,8	78
XS-20-E32-AC	8,0	15100	15070	69,3	69,7	64,9	65,3	86,8	52,64*4	400/47,0	230	5,1	5,2	74
XS-20-E32-EC	8,0	15200	15200	69,5	69,5	64,9	64,9	85,7	65,46*4	-	230	8,6	8,6	74
XS-25-N-AC	7,5	18500	18470	71,1	71,5	66,7	67,3	88,6	-	-	230	6,5	6,6	83
XS-25-N-EC	7,5	19000	19000	71,3	71,3	66,8	66,8	87,5	-	-	230	10,8	10,8	83
XS-25-W-AC	7,5	17000	16970	70,0	70,3	65,5	66,1	87,5	-	-	230	6,7	6,9	98
XS-25-W-EC	7,5	17500	17500	70,3	70,3	65,6	65,6	86,6	-	400/58,6	230	11,0	11,0	98
XS-25-E40-AC	7,5	18500	18470	71,1	71,5	66,7	67,3	88,6	9,5	400/58,6	230	6,5	6,6	89
XS-25-E40-EC	7,5	19000	19000	71,3	71,3	66,8	66,8	87,5	15	400/21,7	230	10,8	10,8	89

*1 Airflow volume according ISO27327-1

*2 Acoustic pressure values at 3 and 5 m distance for maximum speed. Directional factor: Q=2.

*3 Sound power (LWA) measurements according to ISO 27327-2.

*4 Intake air temperature +18°C, at maximum heating level and highest fan speed.

*5 Weight without regulation.

Water exchanger parameters for water temperature gradient of 60/40 °C

Type	Air flow [m³/h]	Heat output [kW]	Outlet temperature [°C]	Water flow [l/s]	Pressure loss [kPa]
XS-15-W-AC	10300	37,6	26,1	0,45	8
XS-20-W-AC	13700	50,2	26,2	0,61	7
XS-25-W-AC	17000	62,7	26,2	0,76	5

* Temperature of intake air: +15 °C

Water exchanger parameters for water temperature gradient of 70/50 °C

Type	Air flow [m³/h]	Heat output [kW]	Outlet temperature [°C]	Water flow [l/s]	Pressure loss [kPa]
XS-15-W-AC	10300	50,4	30,1	0,61	13
XS-20-W-AC	13700	67,6	30,2	0,82	9
XS-25-W-AC	17000	84,5	30,4	1,03	9

* Temperature of intake air: +15 °C

Water exchanger parameters for water temperature gradient of 80/60 °C

Type	Air flow [m³/h]	Heat output [kW]	Outlet temperature [°C]	Water flow [l/s]	Pressure loss [kPa]
XS-15-W-AC	10300	62,9	34,1	0,76	18
XS-20-W-AC	13700	84,6	34,3	1,03	14
XS-25-W-AC	17000	106	34,5	1,29	11

* Temperature of intake air: +15 °C

Water exchanger parameters for water temperature gradient of 90/70 °C

Type	Air flow [m³/h]	Heat output [kW]	Outlet temperature [°C]	Water flow [l/s]	Pressure loss [kPa]
XS-15-W-AC	10300	75,2	38,1	0,92	24
XS-20-W-AC	13700	101	38,4	1,24	17
XS-25-W-AC	17000	127	38,7	1,55	15

* Temperature of intake air: +15 °C

Water exchanger parameters for water temperature gradient of 110/80 °C

Type	Air flow [m³/h]	Heat output [kW]	Outlet temperature [°C]	Water flow [l/s]	Pressure loss [kPa]
XS-15-W-AC	10300	91,3	43,6	0,75	16
XS-20-W-AC	13700	123	43,9	1	12
XS-25-W-AC	17000	154	44,3	1,26	10

* Temperature of intake air: +15 °C

Electric heater parameters

Type	Air flow volume [m³/h]	Heat power [kW]	Electric heater consumption [V/A]	Temperature increase* Δt [°C]
XS-15-E24-AC	11550	24,3	400 / 35,2	6,3
XS-20-E32-AC	15100	32,4	400 / 47,0	6,4
XS-25-E40-AC	18500	40,5	400 / 58,6	6,5

* At the maximum air flow and maximum heater power

Water exchanger parameters for water temperature gradient of 60/40 °C

Type	Air flow [m³/h]	Heat output [kW]	Outlet temperature [°C]	Water flow [l/s]	Pressure loss [kPa]
XS-15-W-EC	10500	37,9	26,0	0,45	8
XS-20-W-EC	14000	50,8	26,1	0,61	7
XS-25-W-EC	17500	63,6	26,1	0,76	5

* Temperature of intake air: +15 °C

Water exchanger parameters for water temperature gradient of 70/50 °C

Type	Air flow [m³/h]	Heat output [kW]	Outlet temperature [°C]	Water flow [l/s]	Pressure loss [kPa]
XS-15-W-EC	10500	50,9	29,9	0,61	13
XS-20-W-EC	14000	68,4	30,1	0,82	9
XS-25-W-EC	17500	85,8	30,1	1,03	9

* Temperature of intake air: +15 °C

Water exchanger parameters for water temperature gradient of 80/60 °C

Type	Air flow [m³/h]	Heat output [kW]	Outlet temperature [°C]	Water flow [l/s]	Pressure loss [kPa]
XS-15-W-EC	10500	63,6	33,9	0,76	18
XS-20-W-EC	14000	85,5	34,1	1,03	14
XS-25-W-EC	17500	108	34,2	1,29	11

* Temperature of intake air: +15 °C

Water exchanger parameters for water temperature gradient of 90/70 °C

Type	Air flow [m³/h]	Heat output [kW]	Outlet temperature [°C]	Water flow [l/s]	Pressure loss [kPa]
XS-15-W-EC	10500	76,0	37,9	0,92	24
XS-20-W-EC	14000	102	38,2	1,24	17
XS-25-W-EC	17500	129	38,3	1,55	15

* Temperature of intake air: +15 °C

Water exchanger parameters for water temperature gradient of 110/80 °C

Type	Air flow [m³/h]	Heat output [kW]	Outlet temperature [°C]	Water flow [l/s]	Pressure loss [kPa]
XS-15-W-EC	10500	92,2	43,3	0,75	16
XS-20-W-EC	14000	124	43,6	1	12
XS-25-W-EC	17500	156	43,8	1,26	10

* Temperature of intake air: +15 °C

Electric heater parameters

Type	Air flow volume [m³/h]	Heat power [kW]	Electric heater consumption [V/A]	Temperature increase* Δt [°C]
XS-15-E24-AC	11400	24,3	400 / 35,2	6,4
XS-20-E32-AC	15200	32,4	400 / 47,0	6,4
XS-25-E40-AC	19000	40,5	400 / 58,6	6,4

* At the maximum air flow and maximum heater power

XS DIMENSIONS

XS...-E-...

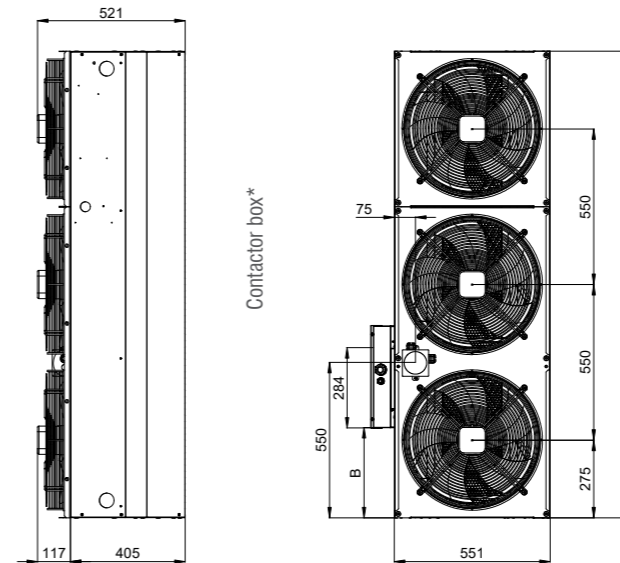

* - Accessories

XS	A [mm]	B [mm]
15	1650	320
20	2200	870
25	2750	870

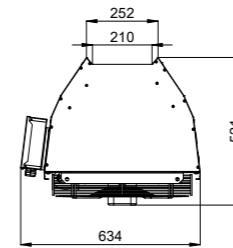

XS...-N-...

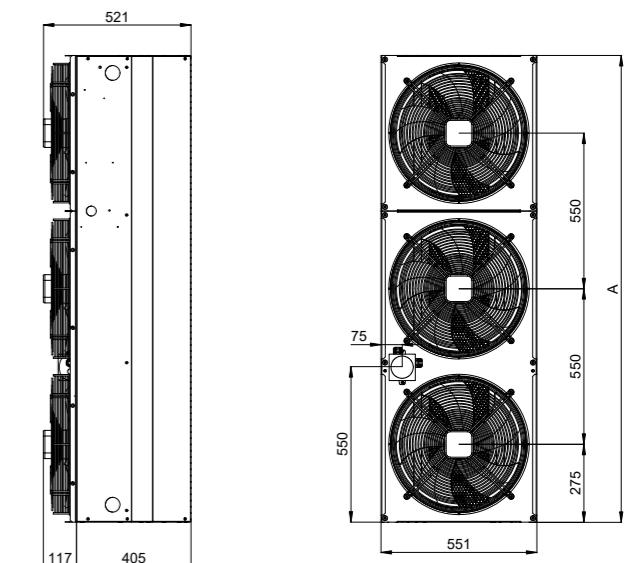

XS	A [mm]
15	1650
20	2200
25	2750

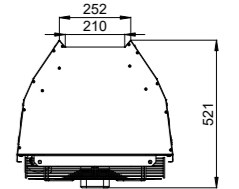

XS...-W-...

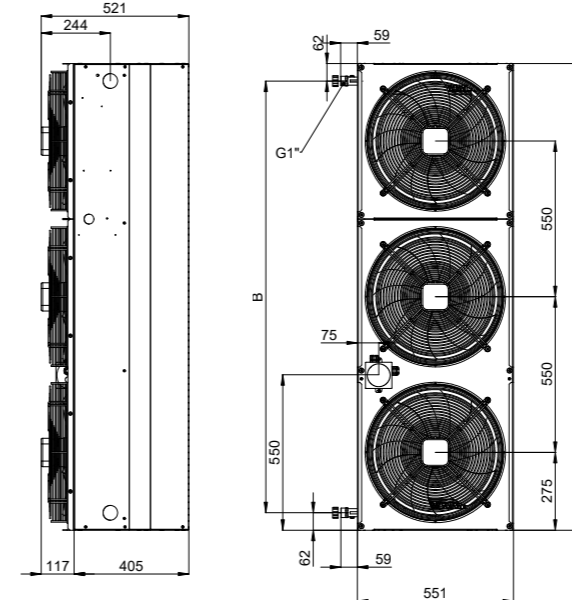

XS	A [mm]	B [mm]
15	1650	1526
20	2200	2076
25	2750	2626

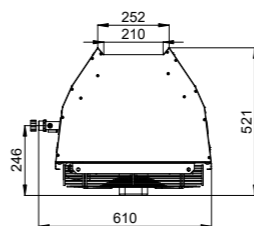

XS...-P2-...

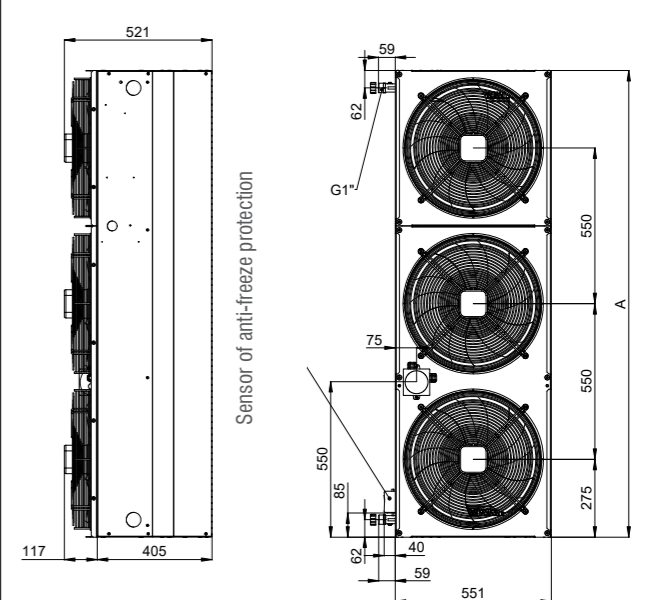

XS	A [mm]
15	1650
20	2200
25	2750

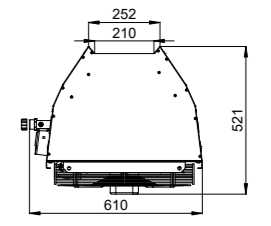

INSTALLATION AND ASSEMBLY

- The air curtain can be installed both in vertical and horizontal positions.
- The air curtain shall be located as close to the top (side) edge of the doorway as possible.
- To ensure correct function it is recommended that the air curtain is located 100 mm above the doorway or overlaps the doorway by 100 mm on both sides.
- Correct operation of the air curtain requires that specified distances from the surrounding objects are observed, see figure.
- Suspension holders are used for installing (hanging) the air curtain see ACCESSORIES.

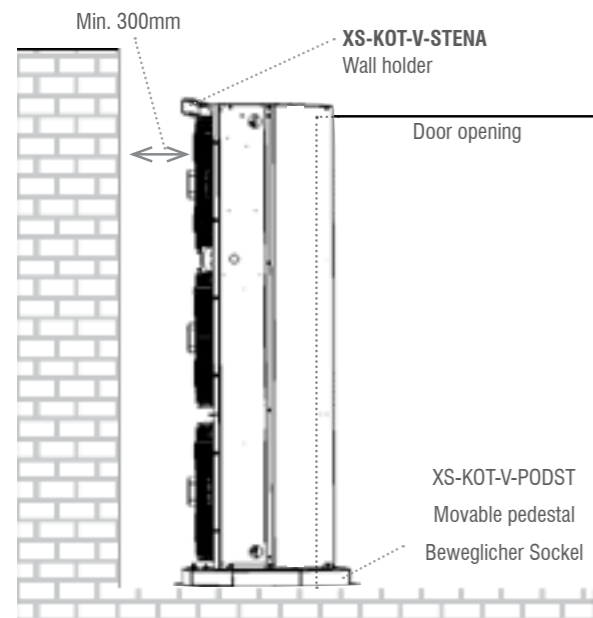
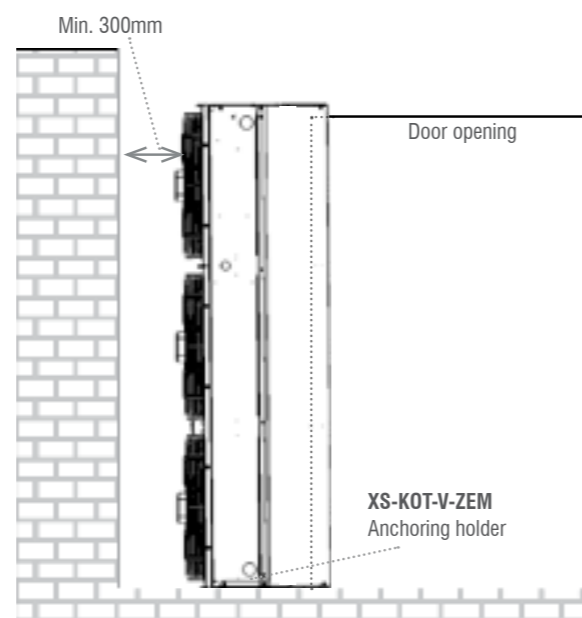
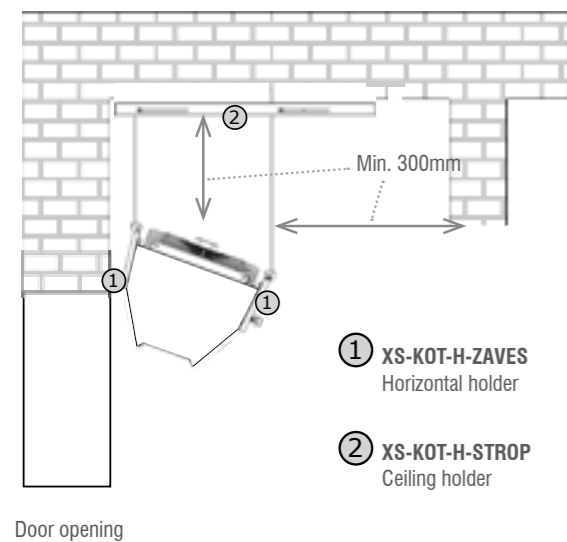
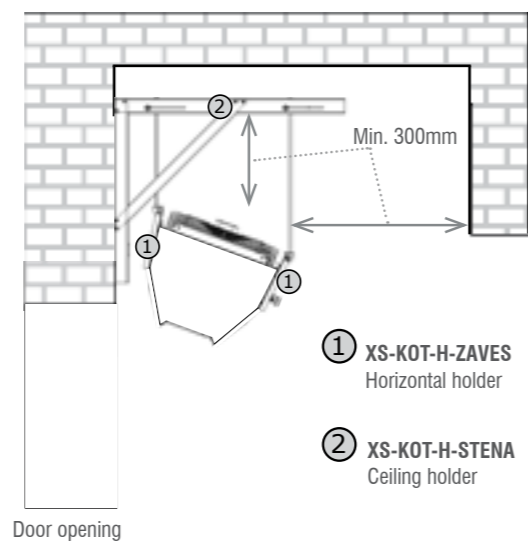
Vertical installation, side view, movable pedestal

Vertical installation, side view, fixed

Vertical installation, side view, movable pedestal

Vertical installation, side view, fixed

CONTROL

- The XS air curtains are shipped without an integrated control system. The following accessories are recommended to allow their regulation.

Possibilities of individual types of controller



	ROVE	STRA1	IC-C
Type of controller	Manual	Manual	Touch
Regulation of air output	5 speeds	5 speeds	5 speeds
Regulation of electric heater	NO	NO	YES
Regulation of water heater	NO	NO	Open / Closed / 0-10V
Possibility of connecting a door contact	NO	YES	YES
Temperature measurement	NO	NO	YES
External control	NO	YES	YES
Integrated Timer	NO	NO	YES
Service indication	NO	YES	YES
Open door indication	NO	NO	YES
Electric heater aftercooling	NO	NO	YES
Antifreeze protection	NO	NO	YES
Chaining of controllers	NO	NO	YES
Light indication of selected function	NO	NO	YES
Control panel lock	NO	NO	YES
BMS capability	NO	NO	YES

The following table states the number of fans in the individual modules of the XS air curtain.

Module type	XS-150	XS-200	XS-250
Number of fans in module	3	4	5

The following table indicates the maximum number of fans for the XS air curtains that can be connected to the individual types of the ROVE controllers.

Controller type	ROVE4	ROVE5
Maximum number of fans connected	3	5

The following table indicates the maximum number of fans for the XS air curtains that can be connected to the individual types of the STRA1 controllers.

Controller type	STRA1-050L22	STRA1-075L22	STRA1-160L20
Maximum number of fans connected	3	6	12

The following table indicates the maximum number of fans for the XS air curtains that can be connected to the individual types of the STRA1 controllers.

Controller type	IC-C AC5-4	IC-C AC5-7	IC-C AC5-16
Maximum number of fans connected	3	6	12

Water heater output control

Precise by mixing

The following table indicates the number of modules of the XS air curtains that should be connected to the individual types of the mixing point.

Type	Number of modules of VCIN					
	1			2		
	K_{vs}	Water flow (m ³ /h)	Min. pump pressure (kPa)	K_{vs}	Water flow (m ³ /h)	Min. pump pressure (kPa)
XS-15	11	2,8	28,5	22	5,5	28,5
XS-20	11	3,7	29,0	22	7,4	29,0
XS-25	11	4,7	34,7	22	9,3	34,7

Suitable combinations of the XS modules and the mixing nodes apply at a water temperature gradient of 80/60, and an inlet air temperature of 15 °C and pressure difference at connection point 5 kPa.

ACCESSORIES

REQUIRED ACCESSORIES

- No special accessories are needed to ensure a proper function of the stand-alone air curtain. If the air curtain is fitted with the control system, the control system is connected using common wiring cables, see the "Wiring diagrams" chapter. A suitable cross-section of the cables, protection of the unit, and utilization of other wiring materials shall be determined based on the particular installation conditions. These components shall be delivered by a company performing the air curtain electrical wiring.

OPTIONAL ACCESSORIES

WALL HOLDER SET - HORIZONTAL

- This set include:
 - A part - Wall holder (1 pcs)
 - B part - Air curtain holder (2 pcs)

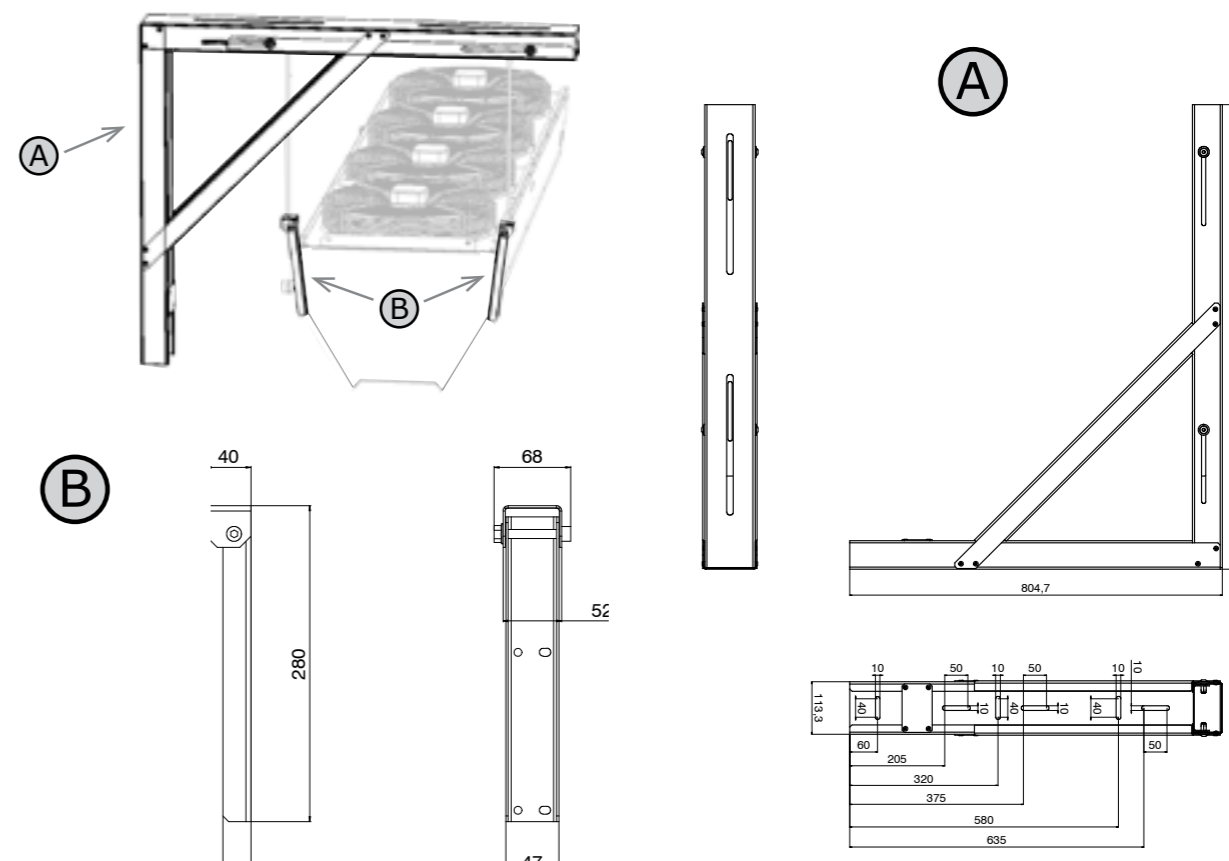

Wall holder set (1 set) **XS-KOT-H-STENA - 0**
 0 Standard (RAL9010)
 1 Galvanized steel
 9 Other RAL
 Color

No. of holders	Number of XS air curtain modules connected									
	1	2	3	4	5	6	7	...	n	
	2	3	4	5	6	7	8	...	n + 1	

OPTIONAL ACCESSORIES

CEILING HOLDER SET - HORIZONTAL

- This set include:
 - A part - Ceiling holder (1 pcs)
 - B part - Air curtain holder (2 pcs)

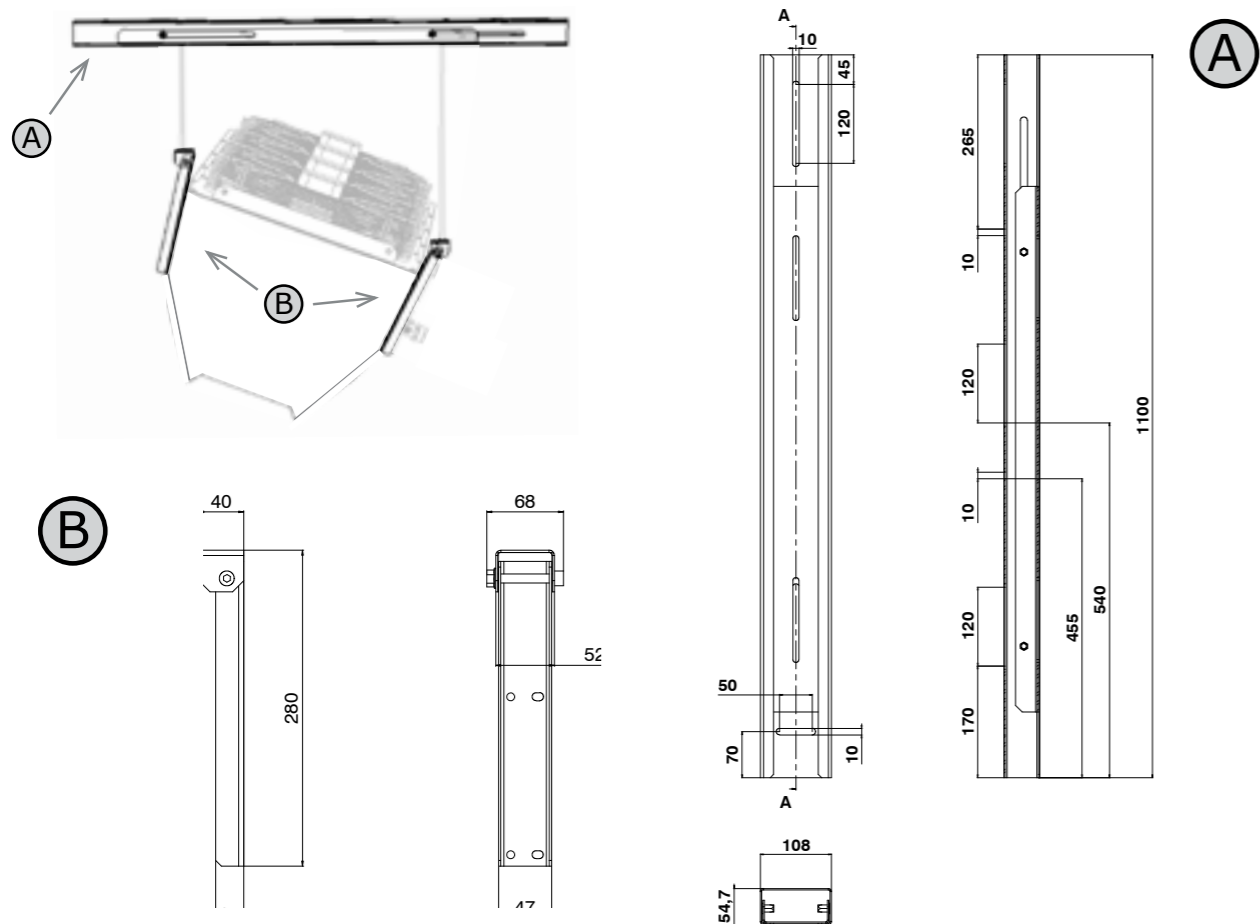

Ceiling holder set (1 set (A+2xB)) **XS-KOT-H-STROP - 0**

- 0 Standard (RAL9010)
 - 1 Galvanized steel
 - 9 Other RAL
- Color

No. of holders	Number of XS air curtain modules connected									
	1	2	3	4	5	6	7	...	n	
	2	3	4	5	6	7	8	...	n + 1	

OPTIONAL ACCESSORIES

WALL HOLDER - VERTICAL

- For anchoring the air curtain to the wall

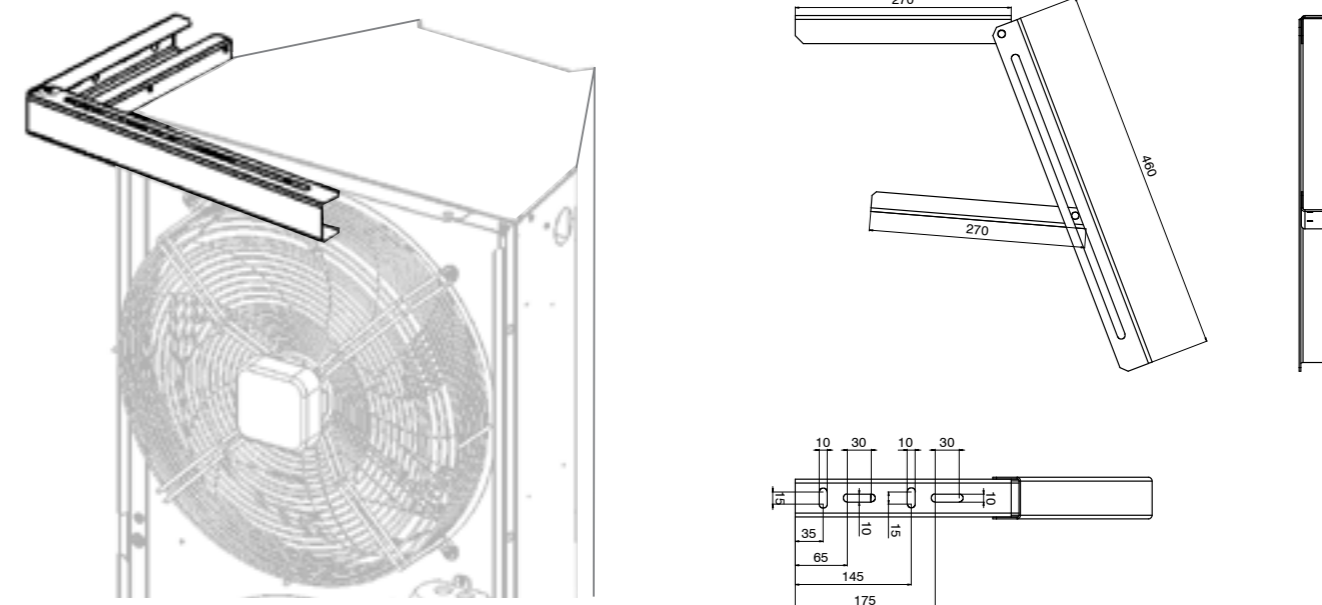

Wall holder (1 pcs) **XS-KOT-V-STENA - 0**

- 0 Standard (RAL9010)
- 1 Galvanized steel
- 9 Other RAL

Color

No. of holders	Number of XS air curtain modules connected			
	1	2	3**	4**
	1*	1*	2	3

* - This holder is not needed up to a height of 4 m, but we recommend to using it.
 ** - The maximum height of air curtains, which can be installed in the vertical position (air curtain on air curtain) is 6,6 m. If you need a higher distance, then an additional supporting system must be made (not supplied by Klimaoprema).

OPTIONAL ACCESSORIES

ANCHORING HOLDER - VERTICAL

- For anchoring the air curtain to the floor

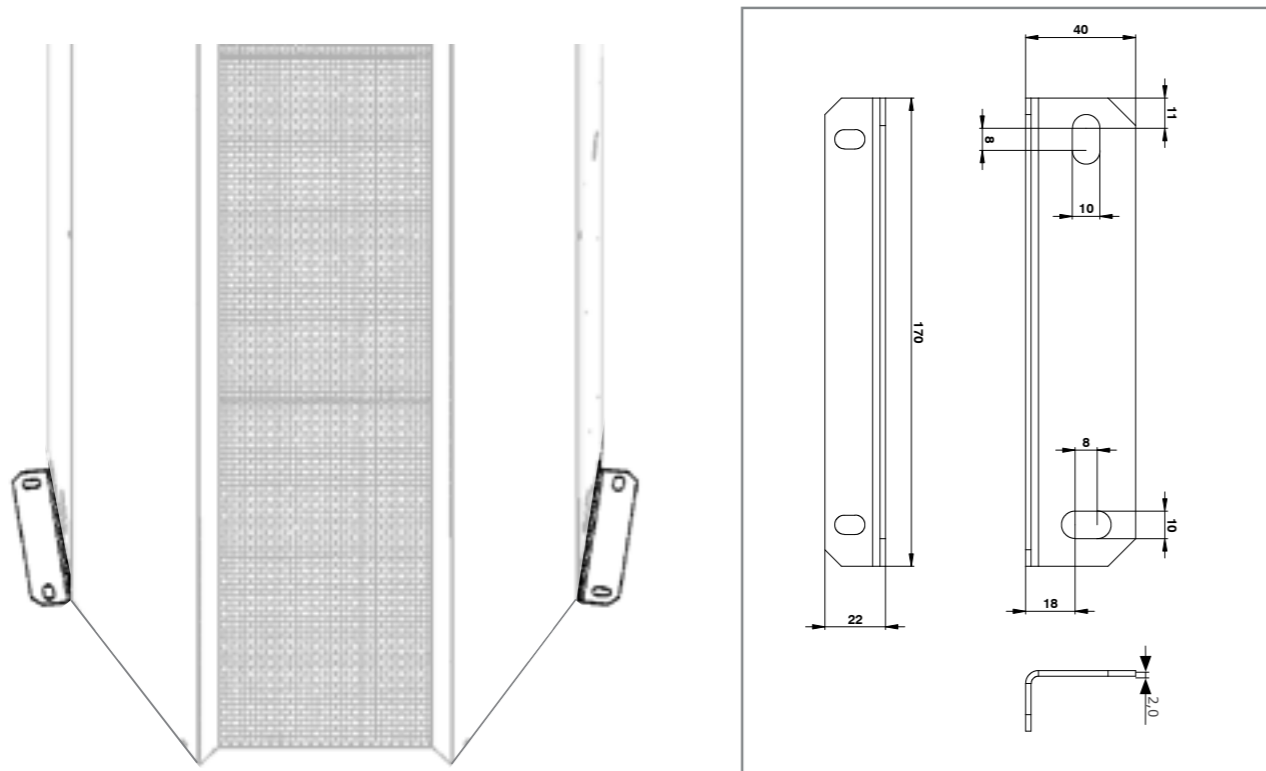

Floor holder set (2 pcs) **XS-KOT-V-ZEM - 0**

- 0 Standard (RAL9010)
- 1 Galvanized steel
- 9 Other RAL

Color

	Number of XS air curtain modules connected			
	1	2	3*	4*
No. of sets of holders	1	1	1	1

* - The maximum height of air curtains, which can be installed in the vertical position (air curtain on air curtain) is 6,5 m. If you need a higher distance, then an additional supporting system must be made (not supplied by Klimaoprema).

OPTIONAL ACCESSORIES

ADJUSTABLE ANCHORING HOLDER - VERTICAL

- For anchoring the air curtain to the floor with the possibility of moving (20° max)

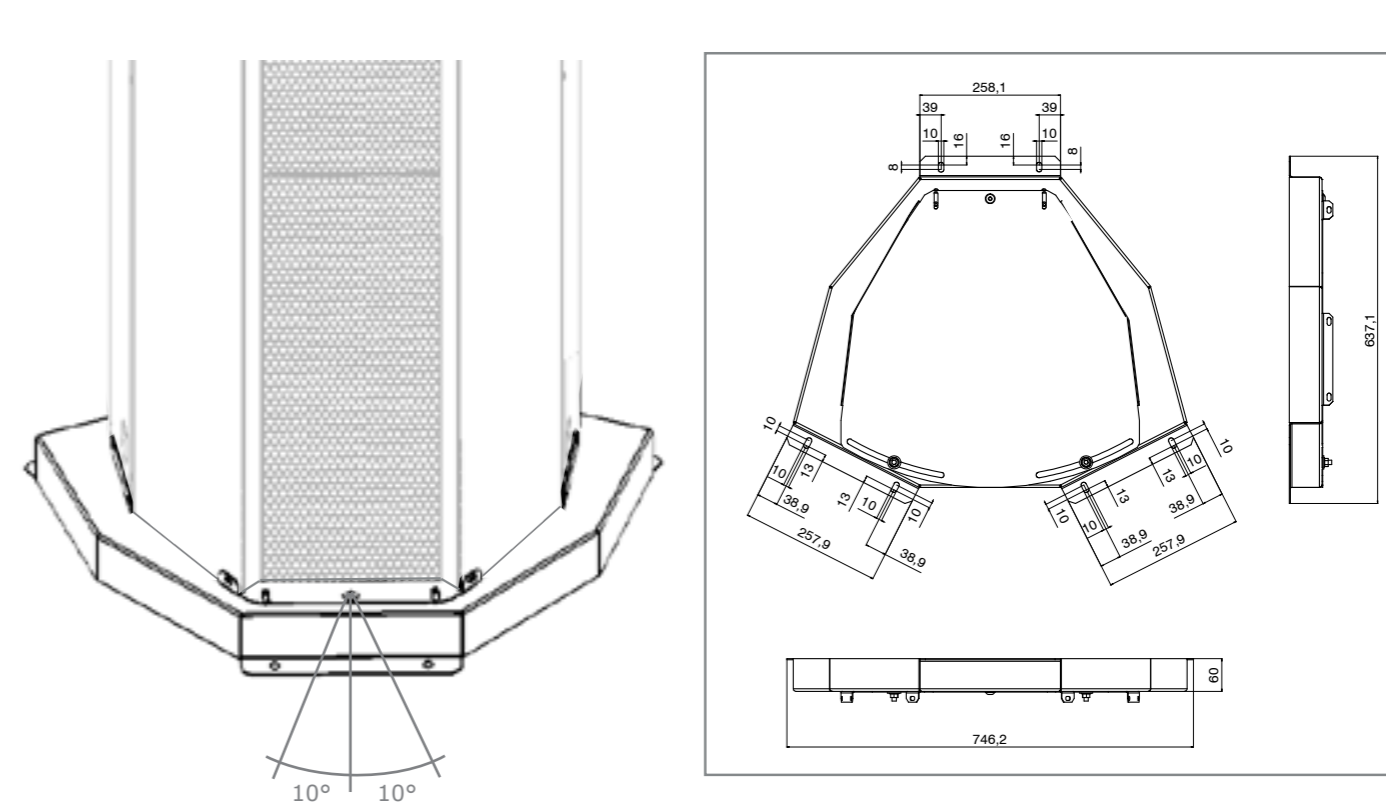

Movable pedestal (1 pcs) **XS-KOT-V-PODST - 0**

- 0 Standard (RAL9010)
- 1 Galvanized steel
- 9 Other RAL

Color

	Number of XS air curtain modules connected			
	1	2	3*	4*
No. of holders	1	1	1	1

* - The maximum height of air curtains, which can be installed in the vertical position (air curtain on air curtain) is 6,6 m. If you need a higher distance, then an additional supporting system must be made (not supplied by Klimaoprema).

OPTIONAL ACCESSORIES

THREADED BAR HOLDER - HORIZONTAL

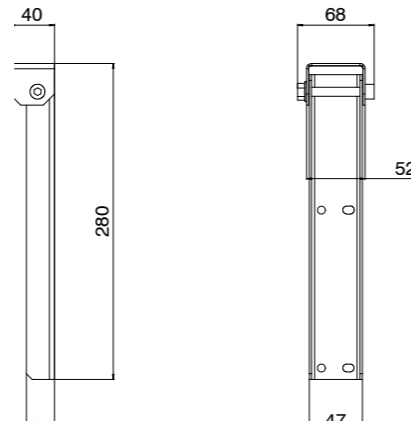
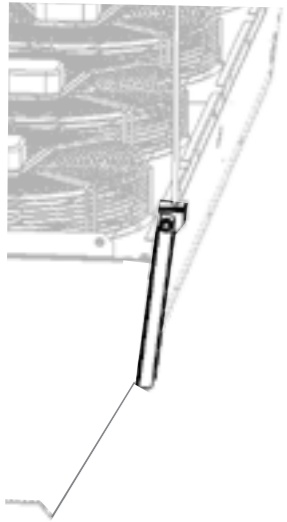

Air curtain holder (1pcs only) **XS-KOT-H-ZAVES - 0**

- 0 Standard (RAL9010)
- 1 Galvanized steel
- 9 Other RAL

Color

No. of sets of holders	Number of XS air curtain modules connected				
	1	2	3	...	n
	4	6	8	...	n*2 + 2

OPTIONAL ACCESSORIES

CONTACTORS BOX

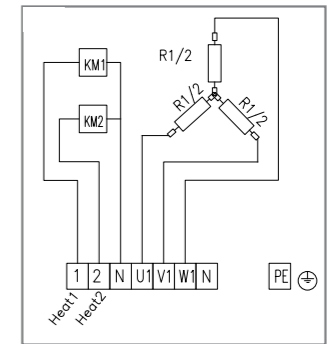
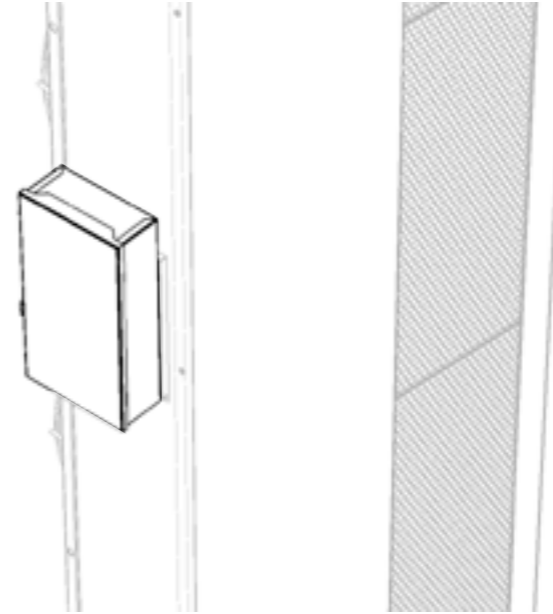

Contactors box (IP20) **XS-KRAB-EL-STYKAC - 25A - 0**

- Max current load**
- 25A** - suitable for: XSA150 or XSA200
- 40A** - suitable for: XSA250
- 0 Standard (RAL9010)
- 1 Galvanized steel
- 9 Other RAL

Color

Motor filter (1 pcs)
FI-PYTEL-KRUH-G2-SAV-4



OTHER ACCESSORIES



Speed controller
ROV



TFlexible connection hoses
OH-01-1/1-300
OH-01-1/1-500



Speed controller
STRA1



Door switch – industrial
DS



Control unit
IC-C



Water valve
RT-3-xx



IC Modbus
IC-M-AC5-04 (07, 16)
Control module for BMS (4A / 7A / 16A)



Mixing node
SMU2-xx-xx

WIRING DIAGRAMS

- The recommended cross-section of the main power supply cables is stated in the Instruction Manual
- All wiring diagrams provided in the technical catalog are indicative only. When assembling the product, strictly observe the nameplate ratings as well as the directions and diagrams affixed directly to the product or enclosed with the product.

XS-xxx-N-AC / XS-xxx-W-AC

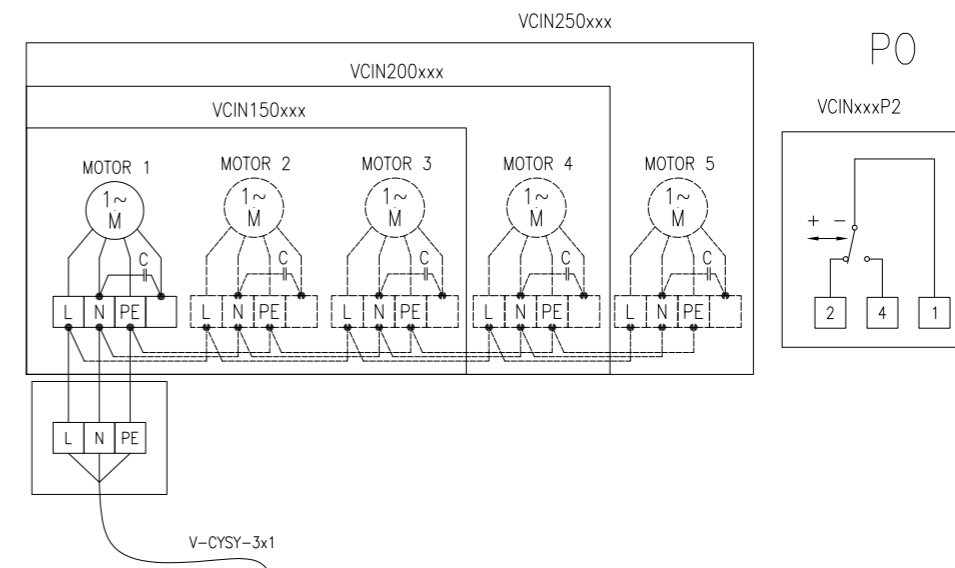

XS-xxx-E-AC

